



BAG FILLING SYSTEMS

www.tdmsunniva.com



Online Catalog



BAG FILLING SYSTEMS

www.tdmsunniva.com

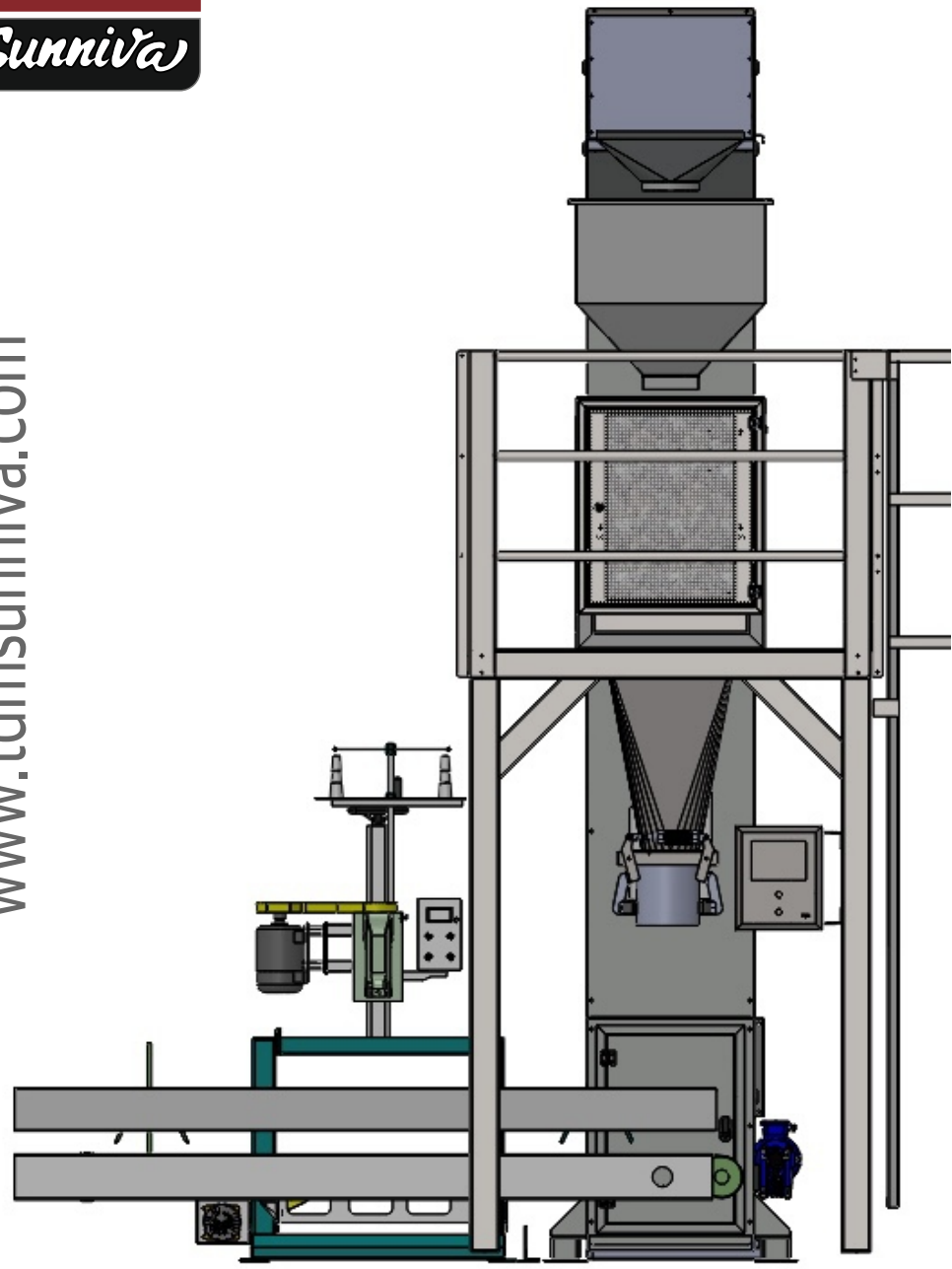

Front View

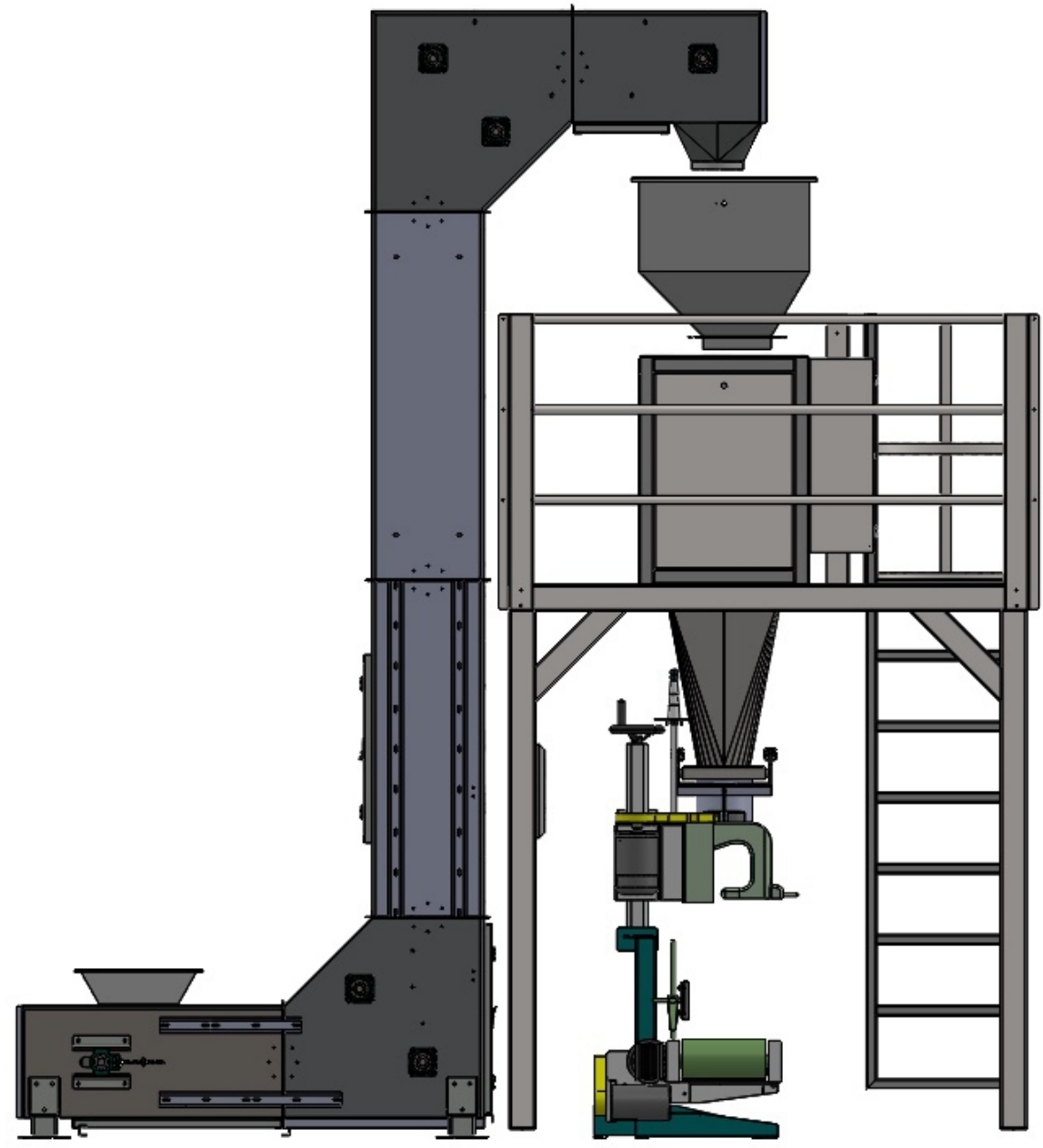

Side View



TECHNICAL SPECIFICATIONS

Body Structure	Painted Steel, The surfaces in contact with the product are stainless steel
Bag Types	Sack, Handle Bag, Gusset Bag, Doypack, Pillow bag, Box
Filling Capacity	12.000 kg / hour
Filling Range	5-50 kg
Accurary	%0,5 gr
Needed Air Pressure	6 bar / 87 PSI
Working Voltage	380 VAC 50 Hz
Line Dimensions	H: 4400 mm L: 3750 mm W:5000 mm
Line Total Weight	2000 kg
Certifications	ISO 9001, GMP, CE
Origin	TURKEY



www.tdmsunniva.com





BOX & BAG FILLING LINE

www.tdmsunniva.com

OPTIONAL VACUUM PACKING MACHINE



12.000 kg/hour Capacity



BOX SEALER MACHINE



DOUBLE HEAD SEWING & SEALER MACHINE



www.tdmsunniva.com

Adalet Mh. Manas Bulvari No:47 Folkart Towers A Kule K:32 D:3202 Bayrakli - Izmir / Turkey
Phone:+90 232 421 26 03 Fax:+90 232 421 2604 Gsm: +90 544 421 2604 E-Mail:sales@tdmsunniva.com